



# NLS-EM2027

## 2D Barcode Scanning Engine

Latest:20081014

### Overview



Designed for OEM application, easily adopted into all kinds of equipments where need the 1D/2D barcode scanning application.

### Product Features



#### Advance Technology

Thanks to the core-technology **UIMG™**. Independent designed and manufactured by Newland Auto-ID. **UIMG™** Technology includes the optical, CMOS, digitizer, decoder, image processing & embedded systems. Supports all global standard 1D barcode symbologies as well as major 2D codes (QR Code, DataMatrix, PDF417, Aztec, Maxicode, Chinese-Sensible Code & LP Code) Reading performance reaches global standard. By using accessories provided, scan all kinds of barcodes defined by customers.



#### Intelligent Focus

Advanced optical focusing system which senses the ambient environment and adjusts the optical automatically for a quick reading response.



# Applicable Accessories

## Quick Set

A platform for 2D barcode scanning configuration based on the Microsoft Windows. Quick set connects the scanner engine thru USB or RS-232, users are able to modify the parameters for scanner engine in real-time through this Windows operation interface.

## Programming Guide

A manual for user who can scans the pre-printed barcodes to define the configuration, by reaching the same functionality as the Quick Set. Reading performance reaches global standard. By using accessories provided, scan all kinds of barcodes defined by customers.

## uTools Lite

A developing tools for the 2D scanning engine based on the Microsoft Windows or Linux. Includes the tools needed for programming likes compiler, C/C++ libraries, user can directly control the scanner engine by those programs, to achieve a self defined decoding.



# Dimension (Unit: mm)

## EM2027 Sensor

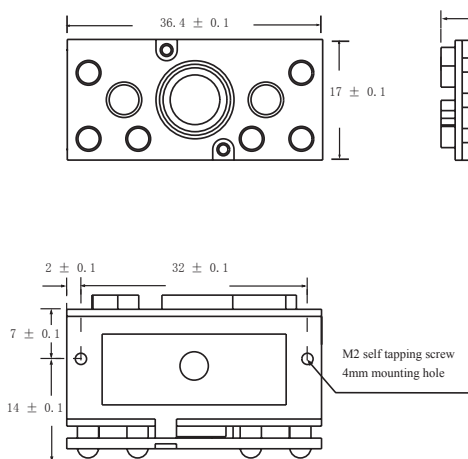

## EM2027M Sensor

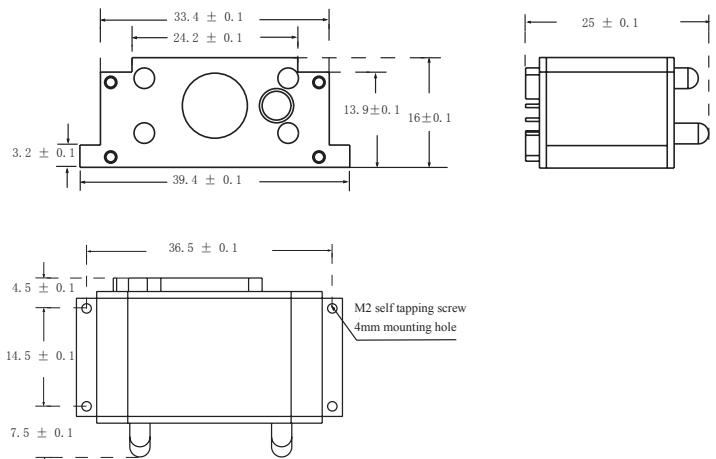

## Decode Board

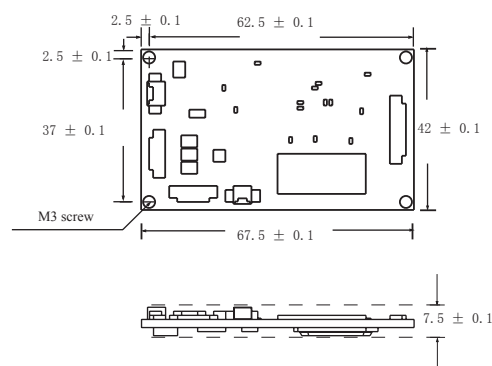



# EM2027 Decode Zones

## Field of View

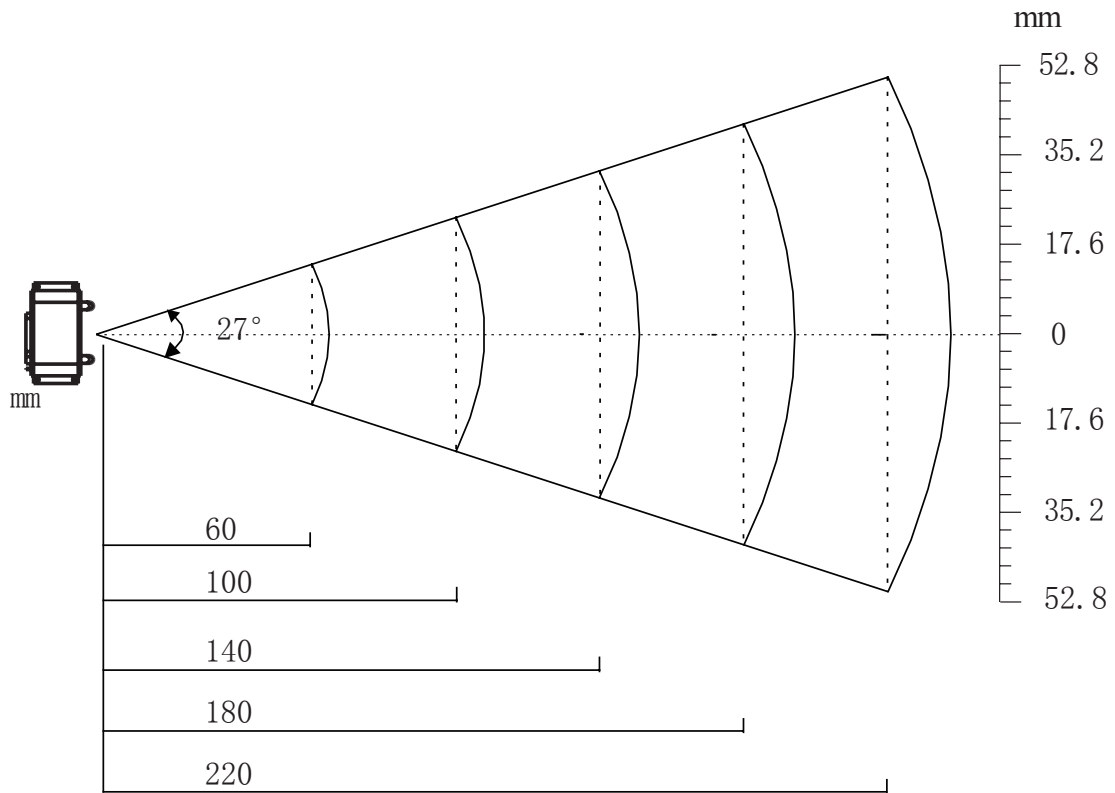

## Decode Distances

Barcode	Density (mil)	Near (mm)	Far (mm)
Code 39	5	65	105
Code 39	10	40	205
PDF417	5	60	95
PDF417	10	40	205
QR Code	10	35	125
QR Code	15	35	200
Data Matrix	10	35	140
Data Matrix	15	30	210



# EM2027M Decode Zones

## Field of View

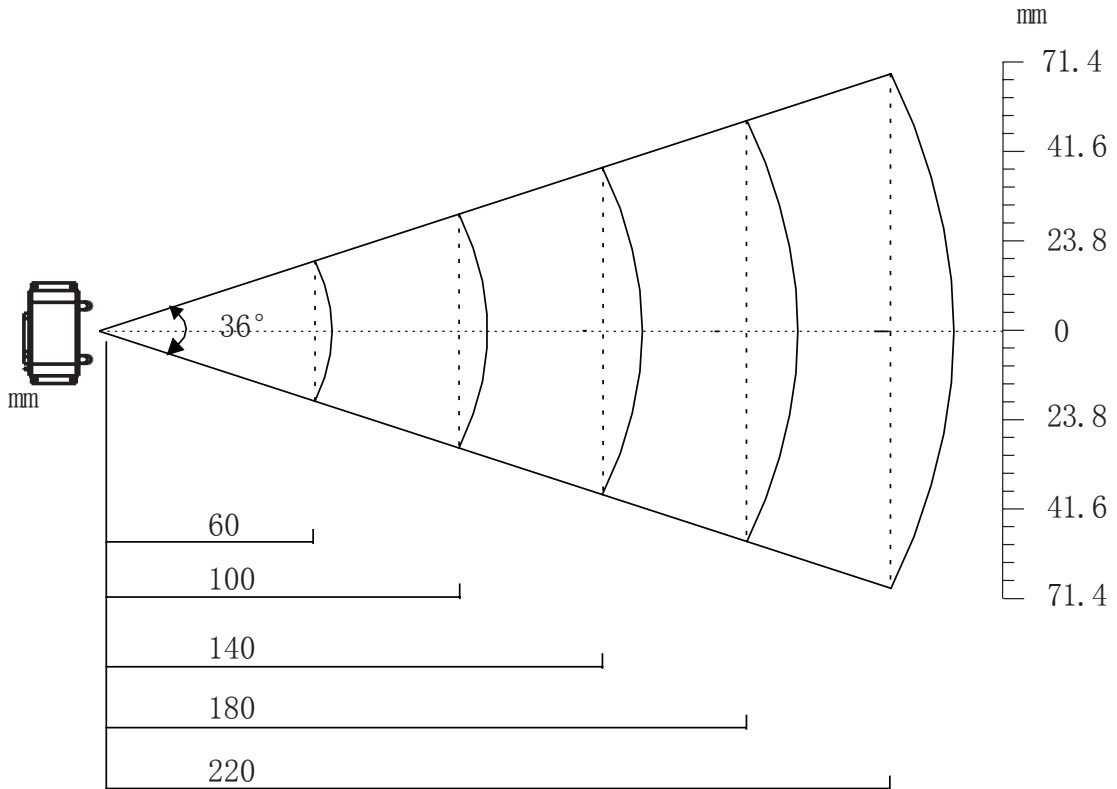

## Decode Distances

Barcode	Density (mil)	Near (mm)	Far (mm)
Code 39	5	55	115
Code 39	10	30	21.5
PDF417	5	50	105
PDF417	10	30	215
QR Code	10	25	135
QR Code	15	25	210
Data Matrix	10	25	150
Data Matrix	15	20	220



# Accessories

## Evaluation Kit

Model	Description
EVK2027	The Evaluation Kit for EM2027, with trigger, beep functions and USB, RS232 interfaces.

## Flex Cable

Model	Description
CBL2027R	This cable connect to the RS232 port of EVK2027 with a RJ45 port. With a standard female RS232 port to connect to standard male RS232 port. With a power port to accept power adapter supply.
CBL2027U	This cable connect to the USB Slave port of EM2027 with a USB-B male port. With a standard USB Slave port to connect to standard USB Host port.

## Power

Model	Description
ADP50	The power adapter for EVK2027 by the CBL2027R. Output: DC5V, 2A; Input: AC100~240V, 50~60HZ.



# Specifications

Performance		
Image Sensor		CMOS
Resolving		EM2027: 640 * 480, EM2027M: 752 * 480
Interface		RS232 / HID-KBW / UDP / USB COM Port Emulation / HID-POS
Symbologies	2D	PDF417, QR Code(Model 1/2), DataMatrix(ECC200, ECC000, 050, 080, 100,140), Aztec, Chinese-Sensible Code, Maxicode, LP Code, etc.
	1D	Code128, EAN-13, EAN-8, Code39, UPC-A, UPC-E, Codabar, China post 25, Interleaved 2 of 5, ISBN/ISSN, Code 93, etc.
Precision		≥ 3mil
Light Source		LED(630 nm ± 10 nm)
Light Intensity		300 LUX (130 mm )
Depth of Scan Field		45 mm ~ 450 mm
Print Contrast Signal		≥ 25%
Roll		360°
Pitch		45°
Yaw		45°
Illumination		0 ~ 100,000 LUX
Electricals		
Power Consumption		2 W
Voltage		DC 5 V
Current	Max	400 mA
	Working	300 mA
	Idle	1 mA
Weight		28 g
Enviroment		
Operate Temperature		-5°C - +45°C
Storage Temperature		-40°C - +60°C
Humidity		5% - 95%(non-condensing)
Programming Software		Quick Set, Programming Guide, uTools Lite
Certification		FCC Part15 Class B, CE EMC Class B